



ERARD®
PRO

**NEW !
SOLUTION GUIDE FOR
PROFESSIONALS**

2024 EDITION



ORGANISATION

TABLE OF CONTENT

TABLE OF CONTENTS

INTEGRATION	10
INTEGRATION OF STANDARD AND BESPOKE FURNITURE ...	10-16
STANDS / FURNITURE	17
HOW TO CHOOSE YOUR STAND ?	18-19
KAMÉLÉO / KAMÉLÉO XXL.....	21-25
E- KROSS	27
KROSS FLIP / KROSS 90°	28-29
KROSS	30-33
XPO	34-37
XPO - KROSS - KAMÉLÉO - ACCESSORIES.....	38-39
KANA	40-42
STANDIT	43-45
WILL.....	46-48
LUX-UP.....	49-50
PLAMSATECH	51-53
HOW TO CHOOSE YOUR VIDEO BAR MOUNT?	54-55
FARGO	56
VISIPLAY	57
SOUNDUP.....	57
OMNIUM	58-59
WINDOWS.....	61
TACTYS	63
SPRING	63
SALAMANDER CARTS	64-65
VISIOTECH	66
CARTOUCH	67
NAGA PRO	69
WOODY	71
RACK PACK.....	72
TOPBOX - WALL MOUNTED	72
ANTITHEFT BOX FOR STANDS.....	73
MAGIC BOX	73
UNIVERSAL ACCESSORIES.....	74
WALL MOUNTS	75
HOW TO CHOOSE YOUR WALL MOUNT ?	76-77
INTEGRA.....	78-79
BOXIT.....	80
SLIDEIT	80
EXO	81-83
EXOSTAND	84
FIXIT	85
TILTIT.....	86
TWISTIT.....	86
MEDIAFIX	87
APPLIK.....	88-91
CLIFF	92-95
FLIP WALL MOUNT / 90° WALL MOUNT	96-97
EASY MOVE.....	98



FREESTANDING VIDEO WALL	100
VIDEO WALL ON XPO STANDS.....	101
POP-OUT WALL MOUNTS	102-103
WALL BOX	104
ANTITHEFT MOUNTS	105
OUTDOOR WALL MOUNTS	106
UNIVERSAL ACCESSORIES.....	107

DESK MOUNTS..... 108

NEXTIA	109-111
FITUP.....	112
TAVOLO.....	113
FITUP 3XL.....	113
NEXTIA - LAPTOP/ TABLET STAND.....	114
PODYS	114
TABLE MOUNT.....	114

CEILING AND POLE MOUNTS..... 115

CEILING MOUNTS FOR 1 SCREEN	115-116
CEILING MOUNTS FOR MULTIPLE SCREENS.....	117
POLE MOUNTS	118

LED VIDEO WALLS

WALL MOUNTING STRUCTURE	120
FREESTANDING STRUCTURE.....	122
LED KIOSKS	124

INDOOR AND OUTDOOR HOUSINGS

INDOOH	126
WALL SCREEN PROTECT	127
POLYCARBONATE COVER	127
UNDERCOVER OUTDOOR HOUSING	128
IP STANDARD	130
OUTDOOH.....	131
DOOHBOX	132-133
DOOHKIOSK.....	134

PROJECTOR MOUNTS

UNIVERSAL CEILING MOUNTS	136-137
CEILING MOUNT WITH ANTITHEFT PLATE.....	138
FUSION	139
VP LIFTS	140
VP LIFTS - ACCESSORIES	141
WALL MOUNTS	142
SHELTER.....	144-145

KAMÉLÉO – FURNITURE FOR COLLABORATIVE SPACES

AN XXL VERSION XXL IS NOW AVAILABLE!



More functionalities as the « standard » version

- Higher stand
- Integrate a large screen while ensuring a sufficient remaining height between the bottom unit and the bottom of the screen to integrate a videobar at 1.1 - 1.2m high
- Sufficient remaining space to integrate also a TopBox

And still....

- Various colors and fronts
- Large choice of screen mounts for any use
- Many accessories

KAMÉLÉO – FURNITURE FOR COLLABORATIVE SPACES

CONFIGURATION TOOL

Online configuration tool accessible from a PC or a smartphone to have a real-time rendering and a SRP price !

Save and validate your project to have a recap of the configuration by e-mail.

Get an accurate quotation on request at adv@erardpro.fr



KAMELEO AND KAMELEO XXL

SKU KAMELEO OR KAMELEO XXL €4,369.00 Excl. Tax SRP

KAMELEO can be fully customized to be totally integrated in your collaborative spaces.

NEW ! Now, KAMELEO is also available in XXL version to integrate large screens with the possibility to have a video bar up to 1.1 et 1.2m high.

NB : colors and finishings of the elements presented below may slightly differ from reality.

VIEWS



TOPBOX

BASE AND COLOUR

FRONT PANELS

<https://kameleo.erardpro.com/en-config.kameleo/>

E-KROSS – MOTORISED MOBILE STAND

ELECTRIC ADJUSTEMENT OF THE HEIGHT OF THE SCREEN



- Mobile stand
- Electric height adjustment for VESA centre (675 mm stroke)
- Screens up to 80kg
- VESA 100x200 > 600x400
- Included accesories: reversible player box, integrated sockets, cable management

Options:

- VESA extension kit 600x600 > 800x600
- Video bar mount with VISIOPLAY (fixing on VESA's screen)

KROSS FLIP / KROSS 90° – MOBILE STAND WITH ROTATIVE SCREEN MOUNT

FOR SAMSUNG FLIP SCREENS BUT NOT ONLY...



Initially designed for SAMSUNG FLIP screen, this stand is also compatible for screens from any brand which will meet the following technical specifications :

- Screens that can manage automatically the portrait/landscape rotation
- Up to 75" max.
- Centered 400x400 VESA
- Max. load : 70kg

Option : glass shelf at the back of the stand

Same SKU as the KROSS FLIP

KROSS STAGE MONITOR

NEW VARIATION IN THE KROSS RANGE FOR OTHER NEEDS



- Available in 2 heights : 40cm and 90cm
- For screens up to 75" max. (according to model)
- Tilting +5°/-15° screen mount
- VESA 200x200 > 600x400
- Max. load : 30kg
- Factory assembled
- Cable management inside profile

KROSS 2000XXL

FOR LARGE SCREENS



- Higher stand to integrate large screens while ensuring an integration of a videobar between 1m and 1.2m high
- For large screens, up to 98"
- Max. load : 120kg
- Available in 4 versions
 - Ø35mm or Ø75mm wheels
 - Factory assembled or to be assembled
- Cable management inside profiles

Accessories

- Large choice of screen mounts for any use
- Many accessories

XPO 2000XXL

FOR LARGE SCREENS



- Higher stand to integrate large screens while ensuring an integration of a videobar between 1m and 1.2m high
- For large screens, up to 98"
- Max. load : 120kg
- Available in 2 versions
 - Mobile
 - Fixed
- Cable management inside profiles
- Factory pre-assembled

Accessories

- Large choice of screen mounts for any use
- Many accessories

KAMÉLÉO – KROSS – XPO ACCESSORIES

TO PERFECT THE AUDIOVISUAL INTEGRATION

- Various **screen mounts** to be chosen according to the **type of screen**
 - Standard screens
 - Large screens
 - Touch screens
 - Screens in portrait mode
 - Side by side dual screen
- **Shelves** to be mounted at the front or at the back of the stand
- **Player boxes** behind the screen
 - Adjustable or not
 - XL player mount: 1m width !
 - **NEW !** XXL player mount
 - Designed for very large screens
 - Ensures the accessibility of AV devices in all situations
- **Numerous videobar mounts !**

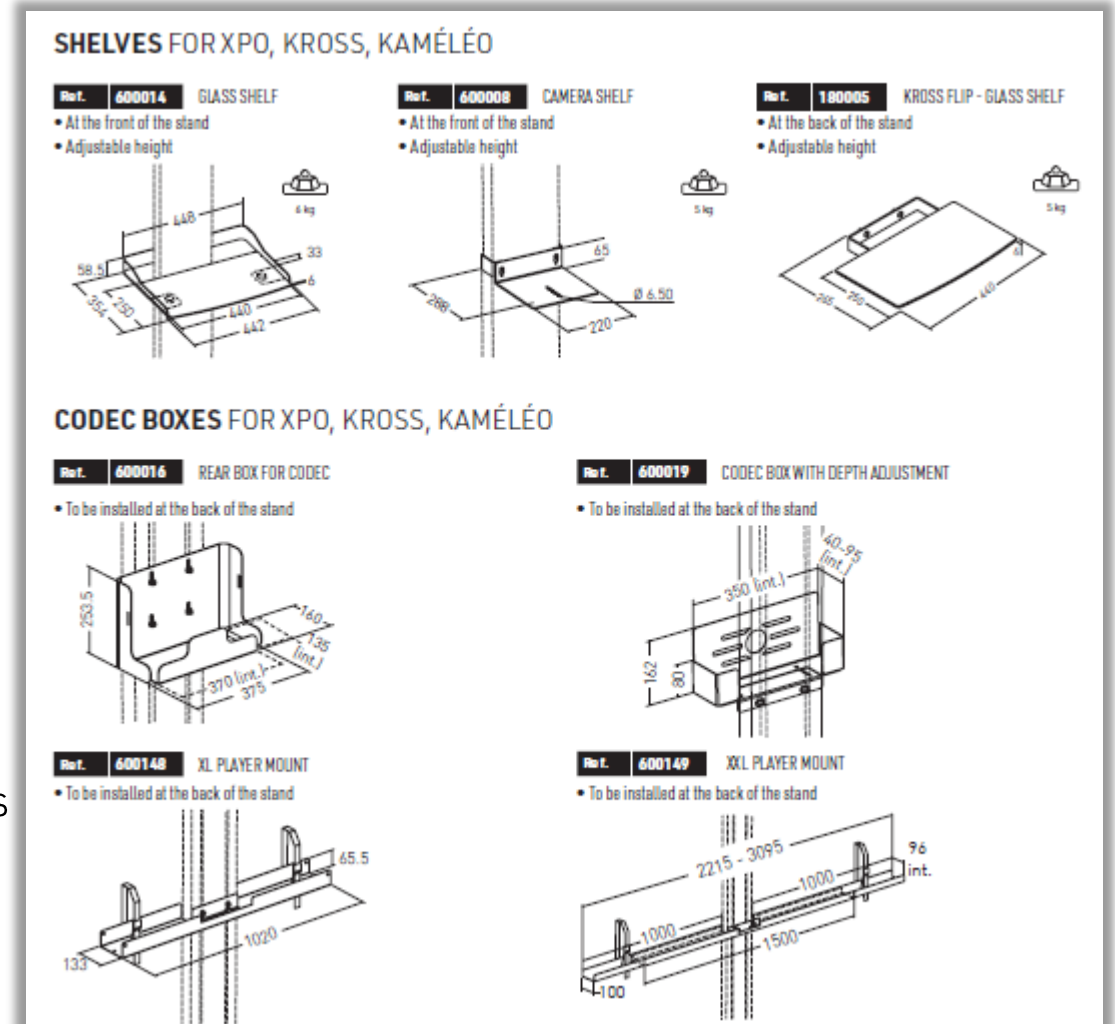

KANA – NEW RANGE

FIXED OR MOBILE STANDS, MADE OF WOOD OR STEEL



2024 NEW ADDITION !

- Stylish and aerial design
- 2 finishings : steel or beechwood
- Available in 3 heights : 1200L; 1400XL, 1600XXL
- Delivered with caster wheels AND fixed feet (choice when assembling by the customer)
- Adjustable screen height along the entire length of the column

OPTIONS :

- Glass shelf
- Player bracket
- Numerous videobar mounts

VIDEOBAR MOUNTS

POLY, LOGITECH, BARCO, YEALINK, CISCO, NUREVA, YAMAHA, CRESTRON, JABRA, AVER, BOSE, LENOVO, NEAT...



POLY, LOGITECH, YEALINK, CISCO, NUREVA, YAMAHA, CRESTRON, JABRA, AVER, BOSE, LENOVO, NEAT...

All these videobars can be easily installed on **KROSS**, **XPO**, **KAMÉLÉO**, **WILL**, **STANDIT**, **LUX-UP** and **KANA** stands.

VIDEOBAR MOUNTS

HOW TO CHOOSE ?

Video bar mounts on stands CHOOSE THE MOUNT FOR YOUR VIDEO BAR

10 YEAR GUARANTEE

New

Choose the right mount in 4 steps

- 1 What is the brand and model of the video bar?
- 2 On which stand will it be installed and would you like it to be above or under the screen?
- 3 No dedicated mount ? Check the compatibility with our universal solutions.
- 4 Is your model of video bar not listed? New references are regularly created, do not hesitate to consult us.

MODEL OF VIDEO BAR NOT LISTED BELOW?
PLEASE, CONSULT US

	XPO - KROSS KAMÉLÉO		STANDIT™ 600 STANDIT™ PRO		WILL		LUX-UP		KANA		VISIOPLAY compatibility	FARGO compatibility
	Under	Above	Under	Above	Under	Above	Under	Above	Under	Above		
LOGITECH	LOGITECH RALLY PLUS (made for 2 speakers + 1 camera + 2 micpods)	600034		039102*		039102				139034		
	LOGITECH RALLY PLUS COMPLET (made for 2 speakers + 1 camera + 2 micpods Includes 2 player racks for TV HUB or TABLE)	602509										
	LOGITECH RALLY BAR	600035		044671		044671				139035	✓	
	LOGITECH RALLY BAR MINI	600035		044671		044671				139035	✓	✓
	LOGITECH RALLY BAR HUDDLE	600035		044671		044671				139035	✓	✓
	LOGITECH MEETUP	600036								139036	✓	with base
POLY	POLY STUDIO	600030		044664		044664		622006		139030	✓	✓
	POLY X30	600046	600045	044668		044668				139046	✓	✓
	POLY R30	600046	600045	044668		044668				139046	✓	✓
	POLY X50	600047	600048	044669		044669				139047	✓	✓
	POLY X52	600047	600048	044669		044669				139047	✓	✓
	POLY X70	600047	600048	044669		044669				139047	✓	✓
	POLY STUDIO E70	600046	600045	044668		044668				139046	✓	✓
	POLY TC8	600008 ou 600014		044662		039080 + 039090		038400		039290		
YEALINK	YEALINK UVC40	600037		044672		044672				139037	✓	✓
	YEALINK A20	600037		044672		044672				139037	✓	✓
	YEALINK A10	600046		044668		044668				139046	✓	✓
	YEALINK A30	600037		044672		044672				139037	✓	✓
	YEALINK UVC34	600046		044668		044668				139046	✓	✓

*Not compatible with STANDIT™ 600

Video bar mounts on stands CHOOSE THE MOUNT FOR YOUR VIDEO BAR

10 YEAR GUARANTEE

	XPO - KROSS KAMÉLÉO		STANDIT™ 600 STANDIT™ PRO		WILL		LUX-UP		KANA		VISIOPLAY compatibility	FARGO compatibility
	Under	Above	Under	Above	Under	Above	Under	Above	Under	Above		
CISCO	CISCO WEBEX ROOM KIT PLUS	600037		044672		044672				139037		✓
	CISCO WEBEX ROOM BAR	600037		044672		044672				139037	✓	✓
	CISCO WEBEX ROOM KIT MINI	600037		044672		044672				139037	✓	✓
NUREVA	NUREVA HDL310 (HDL 300)		600049									
	NUREVA HDL410 (DUAL HDL 300)		600049									
	NUREVA HDL200	600037		044672		044672				139037	✓	
CRESTRON	CRESTRON UC-SB1-CAM-FLEX	600029		044665		044665		622007		139029	✓	
	CRESTRON UC-SB1	600029		044665		044665		622007		139029	✓	
	CRESTRON SB-200	600029		044665		044665		622007		139029	✓	
AVER	AVER VB342+	600029		044666		044666		622008		139029	✓	✓
	AVER VB342PRO	600029		044666		044666		622008		139029	✓	✓
	AVER VB130	600046		044668		044668				139046	✓	✓
BOSE	BOSE VB1	600037		044672		044672				139029	✓	✓
	BOSE VB-S	600046		044668		044668				139046	✓	✓
JABRA	JABRA PANACAST 50	600037		044672		044672				139037	✓	✓
	JABRA CAMERA PANACAST	600046	550201	044668	550201	044668	550201	550201	550201	550201	550201	✓
YAMAHA	YAMAHA CS-800	600037		044672		044672					✓	✓
	YAMAHA CS-700	600031		044663		044663		622006			✓	
	YAMAHA CS-500	600046		044668		044668					✓	✓
	YAMAHA YAS-109	600029									✓	
	YAMAHA ESB-1090	600029									✓	
UNIVERSAL	SOUND-UP	049589	049589	049589	049589	049589	049589	049589	049589	049589	049589	049589
	STAND-ALONE CAMERA SHELF	622001	622001	622001	622001	622001	622001	622001	622001	622001	622001	622001
	VISIOPLAY	049489	049489	049489	049489	049489	049489	049489	049489	049489	049489	049489

Ref. 049490 WALL MOUNT FOR POLY TC8 INTERFACE



- Wall fixing
- For TC8 touch interface for POLY STUDIO X video sound bars
- Black color

*Not compatible with STANDIT™ 600

SALAMANDER – MOTORISED OR FIXED HEIGHT CARTS MADE IN USA

ERARD PRO IS YOUR RESELLER ON THE EUROPEAN MARKET



- Strong and stylish design
- American manufacturing
- Motorised and fixed height carts
- Wired remote for electric carts
- High mobility
- Wheels equipped with brake
- For displays up to 180kg (according to models)
- Lots of accessories

WOODY : FRONT AND BACK DOUBLE-SIDED DOORS

FOR AN EASIER AND EASIER ACCESS TO THE DEVICES

NOUVEAU !

WOODY 12U

Double portes
avant et arrière

4 coloris



WOODY joue l'ouverture !!

*4 portes pour un accès
encore plus facile*



2024 NEW ADDITION

- Replace the former Woody range
- 4 colours
- For 19" rackable device
- Height: 12U
- 270° hinges to access easily to the materials
- Secured locking doors
- Top and bottom cable management
- Natural ventilation thanks to the opened base
- To be assembled / Mounting as an option
- Additionnal rack shelf in option

STORAGE SOLUTIONS

TO PERFECT THE AUDIOVISUAL INTEGRATION



RACK PACK

- 4U unit for 19" rackable devices
- 3 installation modes : stand alone, wall mounting, bolted to the floor
- Secured by a lock



ANTITHEFT BOX ON STANDS AND CARTS

- Compatible with KAMÉLÉO, KROSS, XPO, KROSS FLIP, WILL, LUX-UP, CARTOUCH, VISIOTECH stands
- Secured by a lock



WALL MOUNTED TOPBOX

- Wall mounting kit for TopBOX
- Wall screen mount to be chosen amongst the whole range of ERARD PRO

WALL MOUNTS

HOW TO CHOOSE?

CHOOSE YOUR WALL SCREEN MOUNT IN 3 STEPS

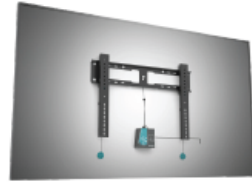

1 What is the weight of your screen?

2 What functions would you like to have?

3 Choose your mount...

... and consult the product page to have more information⁽¹⁾



Tilting



Tilting and swiveling

⁽¹⁾This overview takes into account the technical characteristics of the various displays currently on the market and the specifications of ERARD PRO's mounts. These technical specifications are detailed on product pages of this guide.

ERARD PRO® encourages the user to make his choice by checking the dimensions of the fixing points at the back of the screen (VESA) and the maximum load in kilograms that the mount can accept.

*Anti theft version available. You will find all information on page 105.

	10 kg	15 kg	20 kg	25 kg	30 kg	35 kg	40 kg	45 kg	50 kg	60 kg	70 kg	80 kg	90 kg	100 kg	110 kg	120 kg
CLIFF100 - 043010 P.92																
CLIFF200 - 043020 P.93																
CLIFF400 - 043040 P.94																
CLIFF600 - 043060 P.95																
FK1200 - 044020 P.85																
FK1400 - 044040 P.85																
FK1600 - 044060 P.85																
APPLIX01200 - 012400 P.88																
APPLIX0450007 P.89																
APPLIX12034 - 012430 P.90																
APPLIX002446* / 022446* P.90																
APPLIX2530 - 012530 P.89																
APPLIX2607 - 012607 P.90																
APPLIX012410 / 012419 P.91																
APPLIX012631 / 012632 / 012633 P.91																
INTEGRA 600 - 046000 P.79																
DIXIT - 050210 P.80																
MEDIAFIX 6 - 118000 P.87																
CLIFF100T - 043210 P.92																
CLIFF200T - 043220 P.93																
CLIFF400T - 043240 P.94																
CLIFF600T - 043260 P.95																
TILT1400 - 044240 P.86																
APPLIX2423 - 002423 P.88																
APPLIX045201 / 045202 P.89																
APPLIX2531* - 002531 P.90																
INTEGRA 400T - 046240 P.79																
MEDIAFIX 3 - 118140 P.87																
CLIFF100TWAS - 043310 P.92																
CLIFF100TWH - 043410 P.92																
CLIFF200TWAS - 043320 P.93																
CLIFF200TWH - 043420 P.93																
CLIFF400TWAS - 043340 P.94																
CLIFF400TWH - 043440 P.94																
APPLIX2453 - 002453 P.88																
APPLIX40230 - 040230 P.88																
TWIST1400 - 044410 P.86																
EX0240TW1 - 040220 P.81																
EX0240TW2 - 040220 P.81																
EX0240TW3 - 040220 P.81																
EX0400TW1 - 044140 P.82																
EX0400TW2 - 044240 P.82																
EX0400TW3 - 044340 P.82																
EX0600TW2 - 046200 P.83																
EX0600TW3 - 046300 P.83																
EX0000LTW3 - 044300 P.83																
MEDIAFIX - 118220 / 118440 P.87																

INTEGRA

WALL MOUNTS WITH MAINTENANCE POSITION



- 2 versions available
 - Fixed
 - Tilting
- Wall mount for very large screens
- Maintenance position
- Simple solution to lock/unlock the screen (patented design)
- Horizontal and vertical adjustment of the screen
- VESA 200 > 600x400
- Max. load : 120kg
- Antitheft system in option

FLIP – WALL MOUNT / 90° WALL MOUNT

FOR SAMSUNG FLIP SCREENS BUT NOT ONLY...

Initially designed for SAMSUNG FLIP screen, this stand is also compatible for screens from any brand which will meet the following technical specifications :

- Screens that can manage automatically the portrait/landscape
- Up to 65" max.
- Centered 400x400 VESA
- Max. load : 70kg

- 2 models : with or without connectivity offset
- Same SKU as for Flip – Wall mount

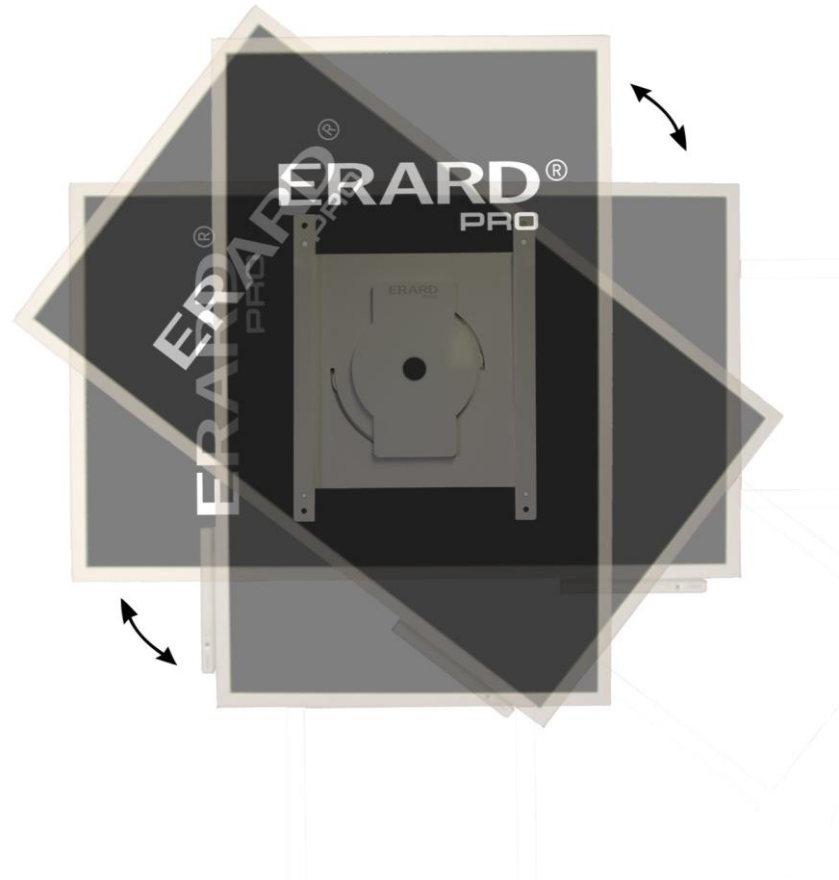

VIDEO WALL ON XPO STANDS

A RELEVANT ALTERNATIVE



An alternative without wall structure !

Can be created with the following XPO stand :

- Floor-wall stands
- Floor-ceiling XPO stands
- Compression XPO stands
- Bolted XPO stands

Must be added (mandatory) :

- Adapter for video wall mount on XPO stands
- Fixed micrometric screen mount OR pop-out mounts

SCREEN WALL MOUNT WITH MICROMETRIC ADJUSTMENTS

PERFECT FOR VIDEOWALLS

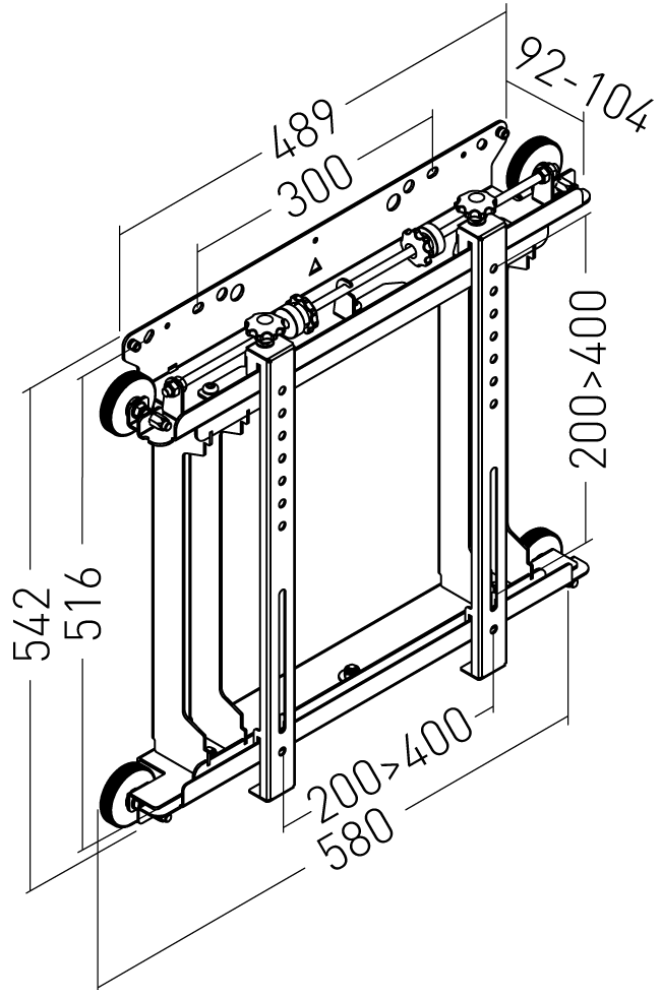

To create videowalls

- Micrometric adjustments on 3 axis for an accurate and perfect alignment of the screens
- VESA 400x400
- VESA extension kits are available for 400x600 or 600x400 VESAs
- Max. load : 50kg

NEW DESK MOUNTS

A GREAT EXPANSION OF THE OFFER



NEXTIA

A COMPLETE RANGE OF DESKTOP SCREEN MOUNTS



NEXTIA is a range of desktop screen mounts designed to contribute to creating comfortable work spaces. This range is composed of 3 types of mounts :

- Mounts with storage space for laptop and/or keyboard
- Mounts with gas springs
- Mounts with manual arms

For all NEXTIA products:

- Tilting and swiveling monitor mount
- Adjustable height of the screen
- No drilling : clamp fixing or stand alone
- Cable management

NEXTIA – LAPTOP STAND

INSTALL THE LAPTOP FOR A COMFORTABLE USE



Accessory for an ergonomic installation of a laptop on the desk

- Foldable and adjustable laptop stand
- Adjustable viewing angle: 6 different levels
- For laptops

FIT-UP 3XL

TAILOR-MADE TABLE TOP MOUNT FOR LARGE SCREENS



- In addition to the FIT-UP range
- Tailor-made product
- For very large screens up to 98"
- VESA : universal in width, 100>600 in height
- Max. load : 85kg
- Max. screen thickness: 50mm

- Other technical specifications on request (according to the project)

TAVOLO

UNIVERSAL TABLE TOP MOUNTS

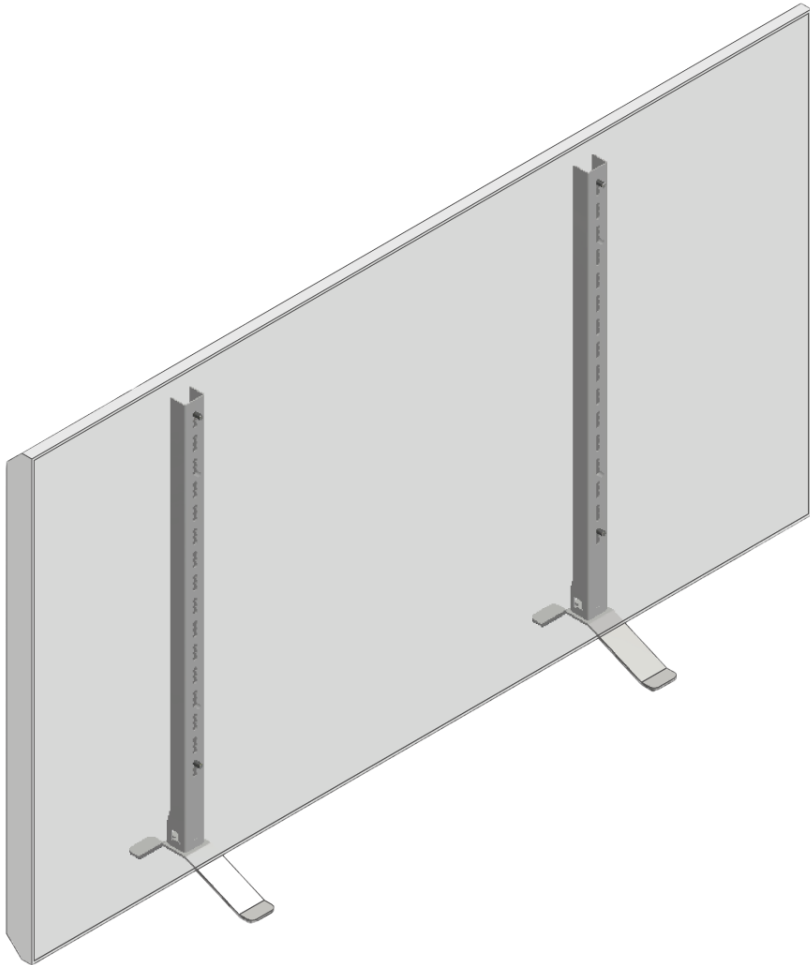

- Alternative to the FITUP range
- 2 versions
 - TAVOLO 400L
 - TAVOLO 600XL
- For all screens / monitors
- Replace any original base
- VESA : universal in width, 100>600 in height
- Max. load: 50kg (according to the model)
- Max. thickness of the screen: 110mm

LED STRUCTURE

ERARD PRO'S KNOW-HOW AT YOUR SERVICE



WALL MOUNTED STRUCTURE FOR LED VIDEOWALLS

NO LIMIT !



With this type of structure, no need of another mechanical structure for your led cabinets.

- Micro-adjustments on the 3 axes for a perfect alignment of LED panels
- Tailor-made design of mechanical parts
- Compatible with all brands and all models of LED cabinets
- For walls of any shape
- Quick and easy mounting

FREESTANDING STRUCTURE FOR LED VIDEOWALLS

NO LIMIT!



With this type of structure, no need of another mechanical structure for your led cabinets.

- Can be installed:
 - Floor
 - Floor-ceiling
 - Ceiling
 - Floor-wall
 - Hanging
- Micro-adjustments on the 3 axes for a perfect alignment of LED panels
- Tailor-made design of mechanical parts
- Compatible with all brands and all models of LED cabinets
- For walls of any shape
- Quick and easy mounting

LED KIOSKS

INDOOR KIOSK FOR ATTRACTIVE INTEGRATIONS



- Bespoke indoor kiosk
- Compatible with all brands and all models of LED cabinets
- LED panels are leveled to the structure
- A magnetic securised back door allows the access to the LED panels
- Space under the panel to install material (player, controller set...)
- Cable management

SHELTER

OUTDOOR ENCLOSURES FOR PROJECTORS



- Outdoor protection housings for projectors
- 2 types of products
 - Installation of the projector in landscape mode
 - Installation of the projector in portrait mode
- Different sizes according to the projector you want to integrate
- Patented product
- IP 54
- Antitheft with several locks
- Heating and ventilation system
- Tilting
- Made in fibreglass

OPTIONS:

- Stackable installations for Shelter V models – mount in options
- Customisable colours

OUR PRODUCTS BUT ALSO...

SOME PICTURES OF AV INTEGRATIONS MADE WITH ERARD PRO'S PRODUCTS

Many pictures of audiovisual integrations made with ERARD PRO's products throughout the new guide



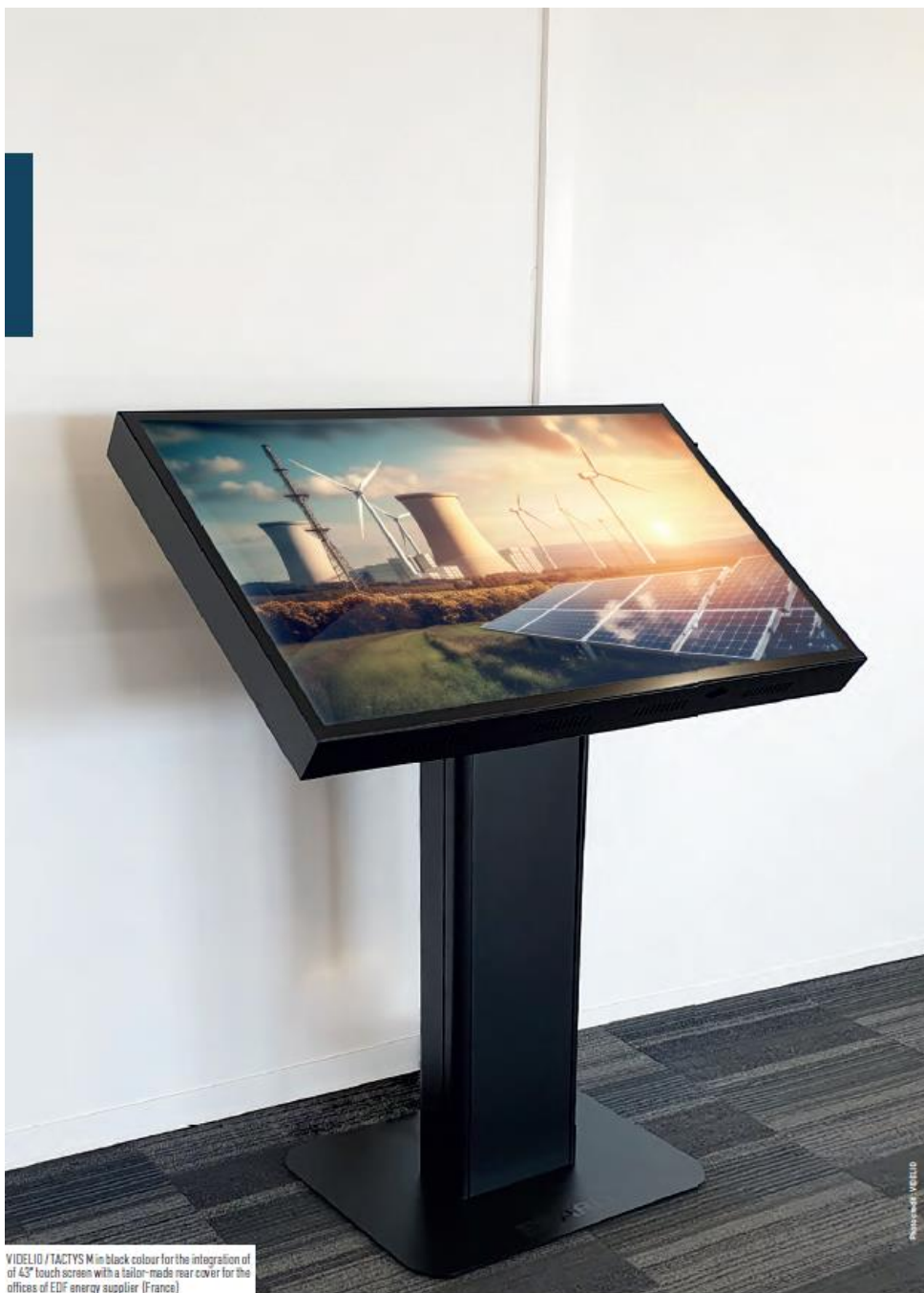

VIDELIO / TACTYS M in black colour for the integration of a 43" touch screen with a tailor-made rear cover for the offices of EDF energy supplier (France)

ERARD®

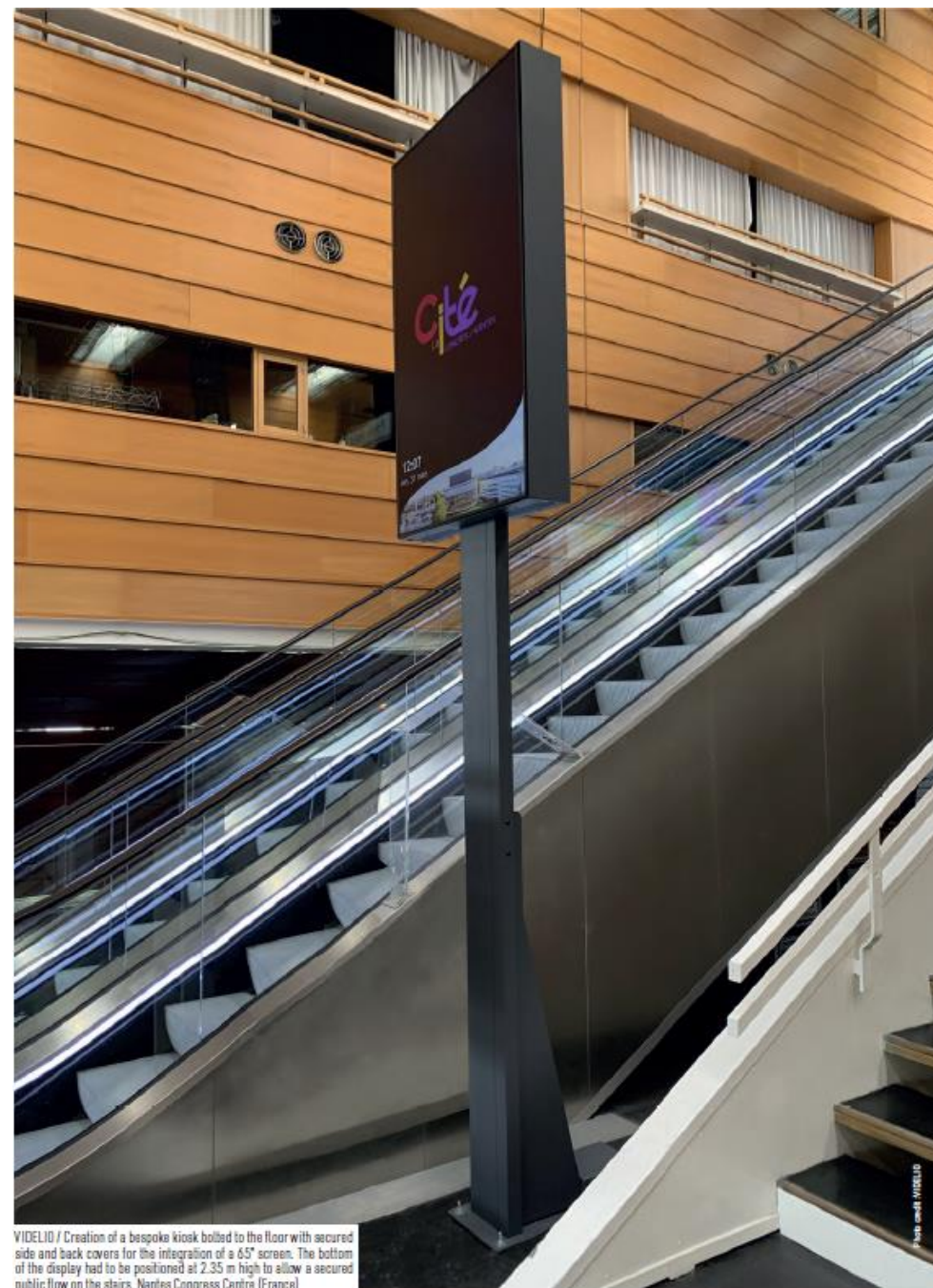

VIDELIO / Creation of a bespoke kiosk bolted to the floor with secured side and back covers for the integration of a 65" screen. The bottom of the display had to be positioned at 2.35 m high to allow a secured public flow on the stairs. Nantes Congress Centre (France)

Photo credit: VIDELIO



VIDELIO and IP Partners / Outdoor DOOHKIOSK housings for 2 back-to-back 65" screens controlled by Tripleplay software installed at LDLC Arena in Décines (France)



PXL Connect / Tailor-made production of a LED video wall of 13m high and 2m width for a company based near Lyon (France). This structure integrates 52 LED cabinets and a full steel coverage with an outdoor treatment.
Reference of LED cabinets : Unilumin Usim-O 3.9 Outdoor



ERARD®
PRO